

### TECHNICAL INFORMATION

Red coil cables 12VDC +/- 15% 243mA  
 Blue coil cables 24VDC +/- 15% 187mA

The ES110 short and ES110 long can both be converted to operate in either Fail Safe (PTL) or Fail Secure (PTO) mode. Simply remove the screw from the top of the strike body to permit removal of the spring and the 3 locking pins (1 x long, 2 x short). It is the placement of these pins in the strike body that will determine the mode of operation. Re-insert pins and spring in order required (refer to the illustrations for guidance). Re-insert brass screws. Replacement pins and spring kit available.

### GENERAL INSTALLATION INSTRUCTIONS

- 1 It is important to note that all rebate strips and/or frame stops are to be fitted before installing these strikes.
- 2 Check with a suitable meter that the regulated power supply or controller being used to operate the strike can provide the required voltage within a +/- 15% tolerance, and that the voltage can be maintained during operation under all circumstances. **WARNING - CONNECTION OF AN INCORRECT VOLTAGE MAY RESULT IN DAMAGE NOT COVERED BY THE PRODUCT WARRANTY.**
- 3 These strikes have been designed for use in weather protected areas and under normal circumstances they do not require any maintenance. **DO NOT OIL OR LUBRICATE.**
- 4 When fitting either the ES110 short or ES110 long to double door sets, the leaf housing the strike must be securely bolted in the closed position during installation and operation, and a rebate strip or frame stop fitted to prevent door travel.

### DOOR LATCH POSITIONING

- 1 To enable the strikes to be located in the frame correctly, first mark the position of the front of the latch tongue on the door frame. Draw a line approx. 65mm for ES110 short or 105mm for the ES110 long vertically from both ends of the latch mark.
- 2 The template sticker enclosed has a line marked "front face of latch tongue" which should be aligned with the line of the door frame. A 1 mm gap has been designed into the template to prevent side load pressure being exerted on the strike release cam when closed.

**NB. TEMPLATES SHOULD NOT BE USED FOR THE FITTING OF LIPLESS MODELS**

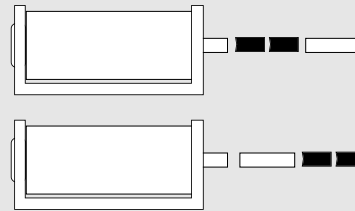

Configuration for Power to Open/Fail Secure

Configuration for Power to Lock/Fail Open

(BS-Wide) ANSI Long Faceplate (BS) ANSI Slim Long Faceplate

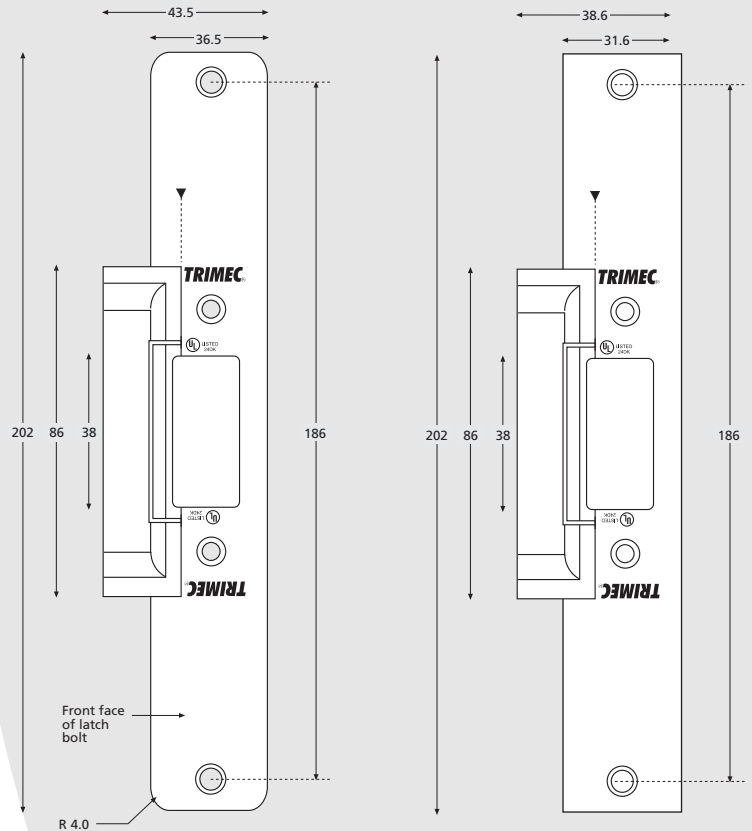

(AS) ANSI Short Faceplate

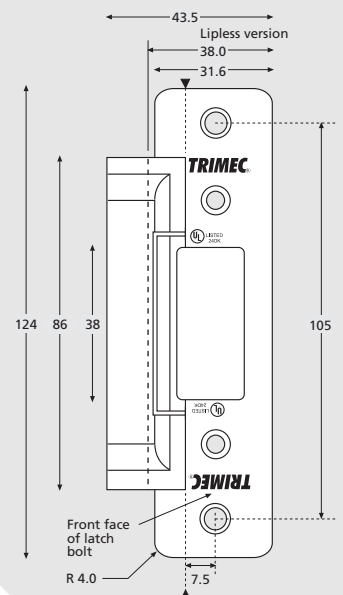

### FITTING THE ES110 SHORT & ES110 LONG STRIKE

- 1 Mortice the doorframe using the template dimensions or the actual body of the strike as the template. Ensure that if the mortice lock being used has a deadlocking snib or trigger, the location of the strike must not allow the snib to enter the "keep" area.
- 2 Position the strike into the mortice and drill the two fixing holes. A set of fixings are supplied for both timber and metal fixing.
- 3 Remove the strike and make the required terminations to the power supply or controller.
- 4 Ensure that all wiring is correctly terminated and not snagged within the mortice. Install the strike back into the mortice temporarily in the correct position and check that there is no mechanical interference between the door, the lock face plate or the strike face and extension lip (if fitted) during the closing cycle.
- 5 Check that no side load pressure is being exerted on the release cam of the strike when the door is closed.
- 6 When all points 1-5 above have been checked and are completed, secure the strike using the correct fixings and re-check operation.

### FOR UL LISTED PRODUCTS

Wiring methods and materials shall be in accordance with the national electrical code, ANSI/NFPA 70-1993.

Must be powered from a UL listed limited energy power source.

**Dynamic Rating:** Highest level

**Static Rating:** Highest Level

**Endurance:** 1 million cycles

### WARRANTY

This product is guaranteed for a period of **5 years** against defects in manufacture, workmanship or materials provided that all electrical and mechanical installation requirements are adhered to as per this instruction sheet. All third party and consequential claims are expressly excluded from this warranty.

### DIODE CONNECTION

The use of the diode for the protection of electrical equipment from transient voltage strikes is recommended.

It is important that the diode is connected correctly, otherwise a short circuit may occur.

Illustrations A & B demonstrate two methods by which you may understand diodes.

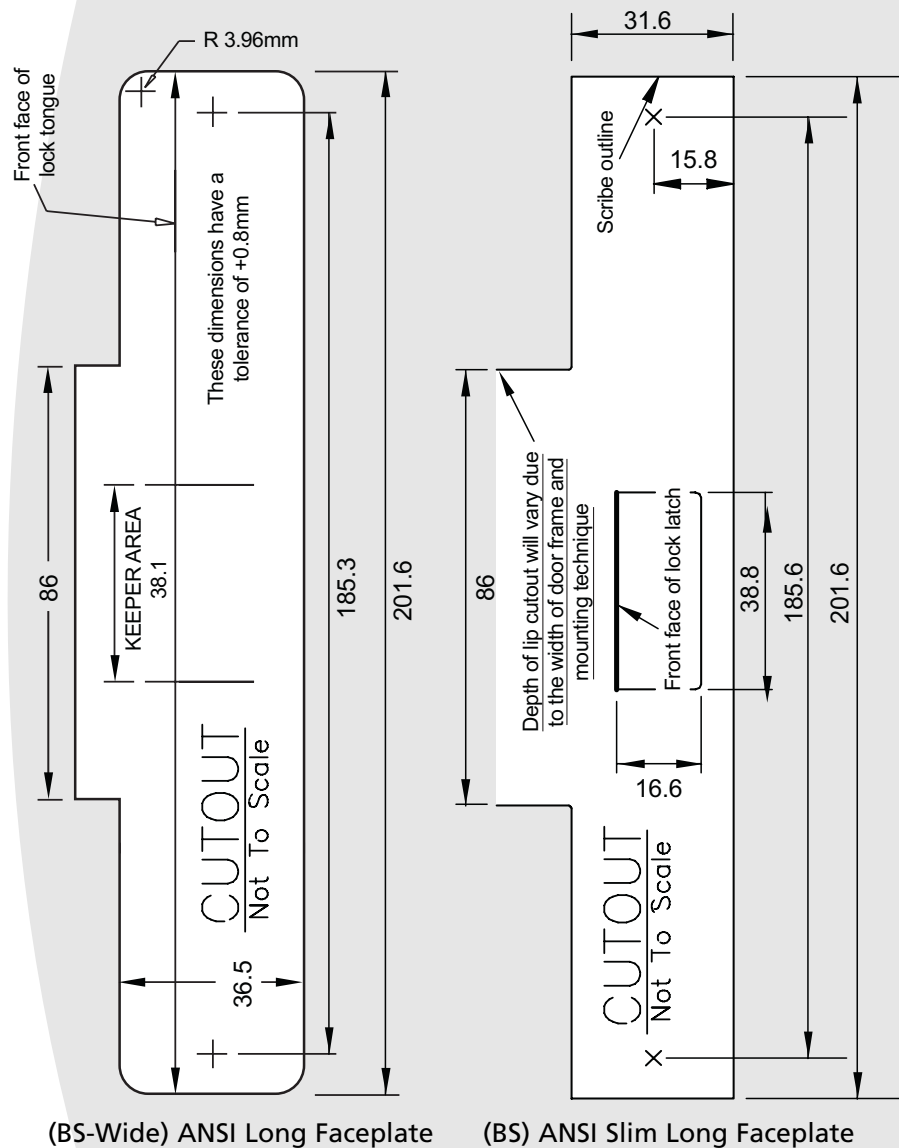

(BS-Wide) ANSI Long Faceplate

(BS) ANSI Slim Long Faceplate

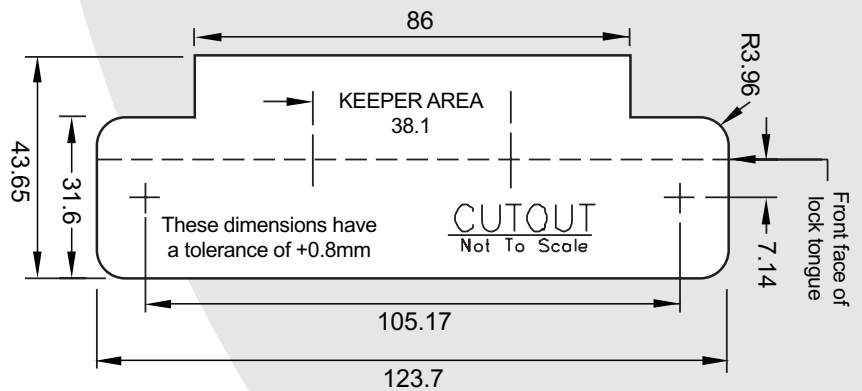

(AS) ANSI Short Faceplate

